

# Trunnion Ball Valves & Double Block and Bleed Valves

Oct, 2022

## AFFCO FLOWCONTROL

Control your flow.





## Trunnion Ball Valves

### Design features of trunnion ball valve

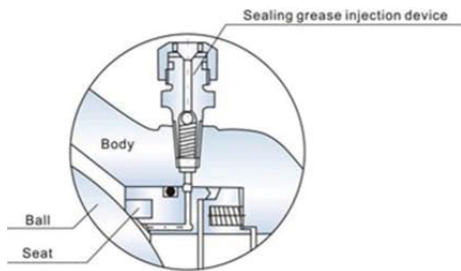

Urgent grease injection device

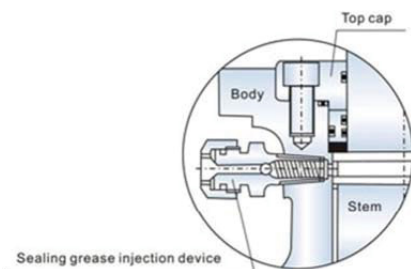

Urgent grease injection device

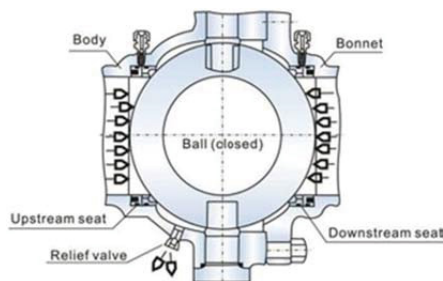

Double block and bleed functions

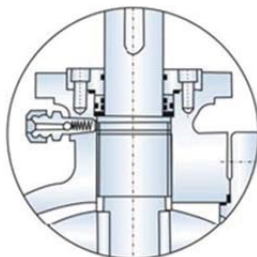

Blow out proof stem design

### URGENT GREASE INJECTION DEVICE

According to customers' requirement, the trunnion ball valves made by our company are provided with devices for urgent grease injection, which are on both the stem and seat for the trunnion ball valves of DN>150mm (NPS6) and in the body cavity for the valve of DN<125mm. When the O ring of stem or the body seat ring is damaged due to accident, the medium leakage between body and stem can be prevented by injecting the sealing grease through the device

### DOUBLE BLOCK AND BLEED FUNCTIONS

In general, our trunnion ball valve features the front ball Sealing design structure. Each seat of the ball valve can separately cut off the medium at both inlet and outlet of the valve to realize double-block functions. When the ball valve is closed, body cavity and two of the body ends can be blocked with each other even if both the inlet and outlet are under pressure, when the medium left in the body cavity might be bled through the relief valve.

### BLOW OUT PROOF STEM

Blow-out proof structure is provided with for the stem, which is positioned by the up-end cap and screw, being guaranteed not to be blown-out by the medium even if at abnormal rising pressure in the cavity.



### SELF-RELIEF IN THE BODY CAVITY

As the liquid medium left in the body cavity gasifies due to increased temperature, the pressure in the body cavity becomes abnormally higher, when the medium itself in the cavity would propel the seat and self-relieves the pressure to ensure the safety of valve.

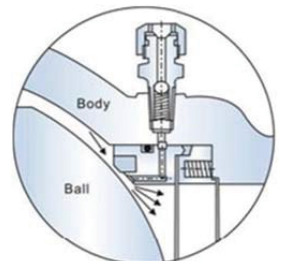

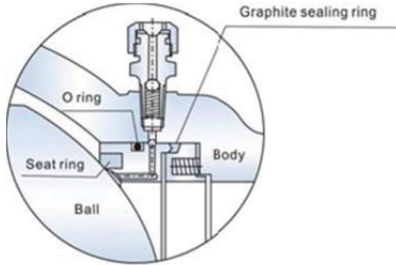

Before fire

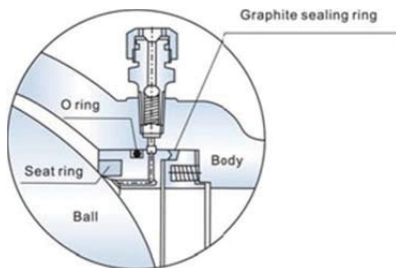

After fire

**Fire safe design of seat**

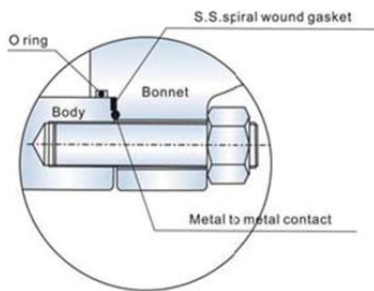

**Fire safe design of valve body and bonnet flanges**

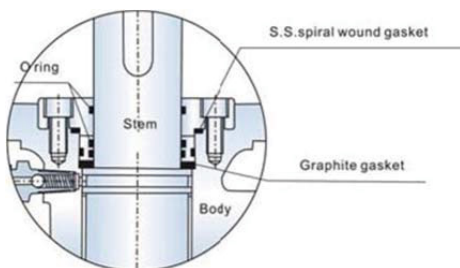

**Fire safe design of stem**

**FIRE-SAFE DESIGN**

With the valve heated in a fire application, the nonmetal material parts such as seat sealing ring of PTFE, O-ring for the stem, and sealing gasket for body and bonnet, might be damaged due to high temperature. Our special design of auxiliary metal to metal or the graphite seal is provided for the trunnion ball valve to effectively prevent: both internal and external leakage of the valve. As required by customers, our fire safe design for the trunnion ball valve meets the requirement of API 607, API 6F and BS6755

**BI-SEALING DESIGN STRUCTURE, (seat sealing in front of the ball and seat sealing behind the ball)**

According to some special working conditions and customers' requirement, we have provided the trunnion ball valve with the BI-sealing design structure, i.e. seat sealing in front of the ball and seat sealing behind the ball, thus the reliable sealing of the valve is ensured because the valve can perform normally even if one of the effective sealing designs becomes lost due to the abnormal condition.

Regarding the seat in front of the ball, the piston effect formed by the area difference between D1 and D2, plus the pre-tightened force of a spring would cause the seat in front of the ball by the pressure difference of the medium before and after the valve to touch the ball closely to form the tightness, of which the sealing force will become bigger as the pressure difference gets higher.

Regarding the seat after the ball, the piston effect formed by the area difference between D2 and D3, plus the pre-tightened force of a spring would cause the seat behind the ball to touch the ball closely to form the tightness, of which the sealing force will become bigger as the pressure difference gets higher.

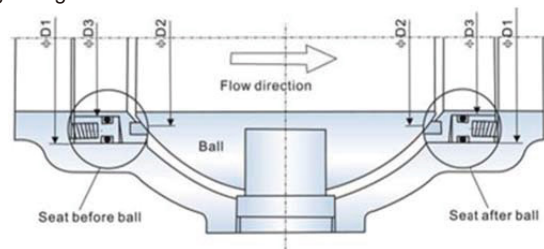

**ANTI-STATIC DESIGN**

The ball of the trunnion ball valve gets close contact with each other through the trunnion, adjusting cushion, and down-end cap, the passage of static electricity thus forms together with the valve, which may lead the static electricity caused by sparks generated by friction between the ball and seat during on and off performance to the ground to prevent the possible risk of fire or explosion.

**MOUNTING PAD PROVIDED**

The trunnion ball valves are provided with a mounting pad for fixing the actuators, such as worm gear, pneumatic, electric, hydraulic actuators.

## Typical drawing of trunnion ball valve and parts composition

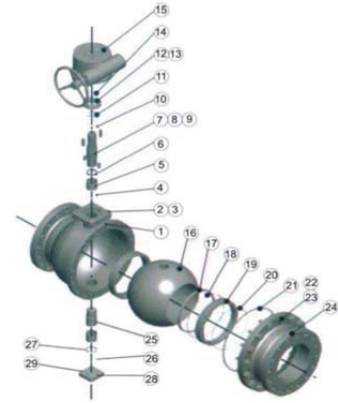

### Application

Trunnion ball valves are suitable for all kinds of pipelines from Class 150 to Class 2500, to cut off or turn on the pipeline medium, of which the operation types include worm gear, manual, pneumatic or electric actuators, being in general of flange connection and butt welding ends connection as well.

### Parts and Material list

Parts No.	Parts Name	Description of Materials				
		WCB(A105N)/13Cr	WCB(A105N)/304	WCB(A105N)/316	CF8(F304)	CF8M(F316)
1	Body	ASTM A216 WCB (ASTM A105N)	ASTM A216 WCB (ASTM A105N)	ASTM A216 WCB (ASTM A105N)	ASTM A351 CF8 (ASTM A182 F304)	ASTM A351 CF8M (ASTM A182 F316)
2	Nut	ASTM A194 2H	ASTM A194 2H	ASTM A194 2H	ASTM A194 2H	ASTM A194 2H
3	Bolting	ASTM A193 B7	ASTM A193 B7	ASTM A193 B7	ASTM A193 B7	ASTM A193 B7
4	O ring	Viton	Viton	Viton	Viton	Viton
5	Stem bearing	Metal backed PTFE	Metal backed PTFE	Metal backed PTFE	Metal backed PTFE	Metal backed PTFE
6	Gasket	ASTM A182 F6a	ASTM A182 F304	ASTM A182 F316	ASTM A182 F304	ASTM A182 F316
7	Stem	ASTM A182 F6a	ASTM A182 F304	ASTM A182 F316	ASTM A182 F304	ASTM A182 F316
8	Key	Carbon steel	Carbon steel	Carbon steel	Stainless steel	Stainless steel
9	Key	Carbon steel	Carbon steel	Carbon steel	Stain loss steel	Stainless steel
10	O ring	Viton	Viton	Viton	Viton	Viton
11	Gasket	PTFE	PTFE	PTFE	PTFE	PTFE
12	Cover	ASTMA105	ASTM A105	ASTM A105	ASTM A182 F304	ASTM A182 F316
13	Cap screw	ASTM A193 B7	ASTM A193 B7	ASTM A193 B7	ASTM A193 B8	ASTM A193 B8M
14	O ring	Viton	Viton	Viton	Viton	Viton
15	Gear Box	Carbon steel	Carbon steel	Carbon steel	Carbon steel	Carbon steel
16	Ball	ASTM A182 F6a	ASTM A182 F304	ASTM A182 F316	ASTM A182 F304	ASTM A182 F316
17	Seat	Reinforced PTFE	Reinforced PTFE	Reinforced PTFE	Reinforced PTFE	Reinforced PTFE
18	O ring	Viton	Viton	Viton	Viton	Viton
19	Seat	ASTM A105	ASTM A105	ASTM A105	ASTM A182 F304	ASTM A182 F316
20	Spring	SS304 or Inconel 750	SS304 or Inconel 750	SS316 or Inconel 750	SS304 or Inconel 750	SS316 or Inconel 750
21	Gasket	Viton or PTFE or Graphite	Viton or PTFE or Graphite	Viton or PTFE or Graphite	Viton or PTFE or Graphite	Viton or PTFE or Graphite
22	Body bolting	ASTM A193 BZ	ASTM A193 BZ	ASTM A193 BZ	ASTM A193 B8	ASTM A193 B8M
23	Body nut	ASTM A194 2H	ASTM A194 2H	ASTM A194 2H	ASTM A194 8	ASTM A194 8M
24	Closure	ASTM A216 WCB (ASTM A105)	ASTM A216 WCB (ASTM A105)	ASTM A216 WCB (ASTM A105)	ASTM A351 CF8 (ASTM A182 F304)	ASTM A351 CF8M (ASTM A182 F316)
25	Lower trunnion	ASTM A182 F6a	ASTM A182 F304	ASTM A182F316	ASTM A182 F304	ASTM A182 F316
26	O ring	Viton	Viton	Viton	Viton	Viton
27	Gasket	ASTM A182 F6a	ASTM A182 F304	ASTM A182 F316	ASTM A182 F304	ASTM A182 F316
28	Lower cover	ASTM A105	ASTM A105	ASTM A105	ASTM A182 F304	ASTM A182 F316
29	Cap screw	ASTM A193 B7	ASTM A193 B7	ASTM A193 B7	ASTM A193 B8	ASTM A193 B8M

Note: The chart above only lists out some common composition of steel ball valve parts. We may provide other different parts material composition according to the customer's request or the actual valve working condition.

## Main size and weight

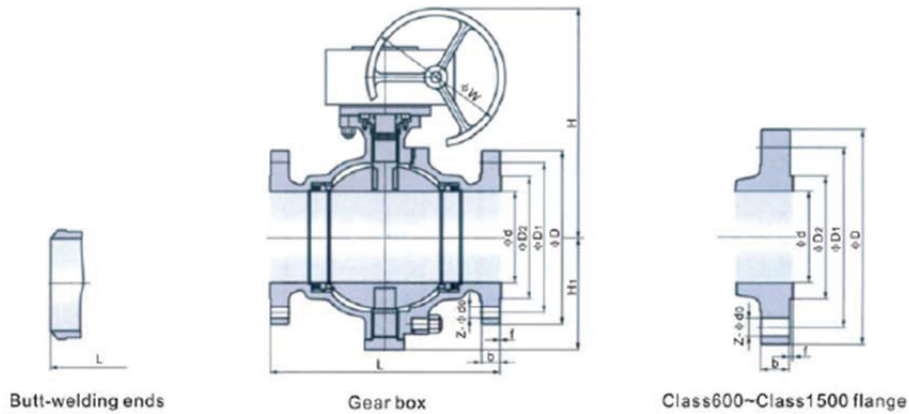

Pressure Rating	Size		Dimensions(mm)					Weight(kg)	
	DN	NPS	L		d	H	H1		W
			RF	BW					
Class150	100	4	229	305	102	330	135	300	60
	125	5	356	381	127	360	165	300	60
	150	6	394	457	152	392	193	300	101
	200	8	457	521	203	492	240	300	166
	250	10	533	559	254	548	293	300	283
	300	12	610	635	305	688	340	400	463
	350	14	686	762	337	722	372	400	622
	400	16	762	838	387	722	415	400	900
	450	18	864	914	438	804	462	500	1150
	500	20	914	991	489	952	511	600	1360
	600	24	1067	1143	591	1154	601	750	2514
	650	26	1143	1245	633	1300	700	750	3200
	700	28	1245	1346	684	1550	780	750	4000
	750	30	1295	1397	735	1650	830	750	4800
800	32	1372	1524	779	1740	870	750	5800	
900	36	1524	1727	874	1950	970	750	8000	
Class300	100	4	305	305	102	340	140	300	70
	125	5	381	381	127	370	170	300	95
	150	6	403	457	152	402	192	300	128
	200	8	502	521	203	498	246	300	234
	250	10	568	559	254	655	303	400	403
	300	12	648	635	305	658	348	400	602
	350	14	762	762	337	686	378	400	803
	400	16	838	838	387	880	429	600	1273
	450	18	914	914	438	1050	518	750	1450
	500	20	991	991	489	1110	540	750	1700
	600	24	1143	1143	591	1400	650	750	3100
	650	26	1245	1245	633	1500	750	750	4500
	700	28	1346	1346	684	1600	800	750	6000
	750	30	1397	1397	735	1720	860	750	7500
800	32	1524	1524	779	1800	900	750	9000	
900	36	1727	1727	874	2200	1020	600	12000	



## Trunnion Ball Valves

Pressure Rating	Size		Dimensions(mm)							Weight(kg)
	DN	NPS	L			d	H	H1	W	
			RF	RTJ	BW					
Class600	50	2	292	295	292	51	240	94	300	32
	65	2 1/2	330	333	330	64	290	115	300	47
	80	3	356	359	356	76	340	136	300	68
	100	4	423	435	432	102	358	152	300	106
	125	5	508	511	508	127	400	180	300	170
	150	6	559	562	559	152	445	209	400	241
	200	8	660	664	660	203	498	263	400	444
	250	10	787	791	787	254	653	312	400	668
	300	12	838	841	838	305	665	354	500	1050
	350	14	889	892	889	334	738	389	600	1317
	400	16	991	994	991	385	920	440	750	1800
	450	18	1092	1095	1092	436	1100	530	750	2400
	500	20	1194	1200	1194	487	1200	560	750	3000
600	24	1397	1407	1397	538	1480	670	750	5400	
Class900	50	2	368	371	368	51	250	96	300	45
	65	2 1/2	419	422	419	64	300	120	300	55
	80	3	381	384	381	76	345	140	300	94
	100	4	457	460	457	102	415	162	300	141
	125	5	559	562	559	127	446	188	300	230
	150	6	610	613	610	152	477	213	400	325
	200	8	737	740	737	203	520	270	400	580
	250	10	838	841	838	254	628	322	400	850
	300	12	965	968	965	305	680	360	500	1330
	350	14	1029	1038	1029	322	750	400	600	1660
400	16	1130	1140	1130	373	940	460	750	2280	
Class1500	40	1 1/2	305	305	305	38	280	100	300	44
	50	2	368	371	371	51	320	113	300	67
	65	2 1/2	419	422	422	64	340	125	300	80
	80	3	470	473	473	76	385	138	300	130
	100	4	546	549	549	102	415	171	300	192
	125	5	673	676	676	125	480	200	400	335
	150	6	705	711	711	144	580	222	400	475
	200	8	832	841	841	192	584	280	400	820
	250	10	991	1000	1000	239	650	340	500	1320
300	12	1130	1146	1146	287	700	370	600	2050	
Class2500	40	1 1/2	384	387	384	38	290	105	300	72
	50	2	451	454	451	42	320	120	300	104
	65	2 1/2	508	514	508	52	350	130	300	140
	80	3	578	584	578	62	400	150	300	202
	100	4	673	683	673	87	425	180	400	305
	125	5	794	807	794	100	500	210	400	530
	150	6	914	927	914	131	590	230	500	760
	200	8	1022	1038	1022	179	610	290	500	1200
250	10	1270	1292	1270	223	660	350	600	2080	

**Notes:**

1, RF indicates raised flange, RTJ means ring joint flange, and BW is butt welding connection.

2, Flange dimensions of the above table for valves of NPS<=24 conforms to ASME B16.5.

3, For valves of NPS>=26, the flange dimensions of above table conforms to 8 series of ASME B16.47 and API 605. As required by customers, flange dimensions may also conform to A series of ASME B16.47 and MSS-SP-44.

### **Metal Seated Ball Valve**

In general metal seated trunnion ball valves are offered with cast steel, however as per project and customer requirements AFFCO can provide forged steel metal seated trunnion ball valves as well. The flange dimensions and face to face dimensions are same for both cast and forged steel trunnion ball valves.

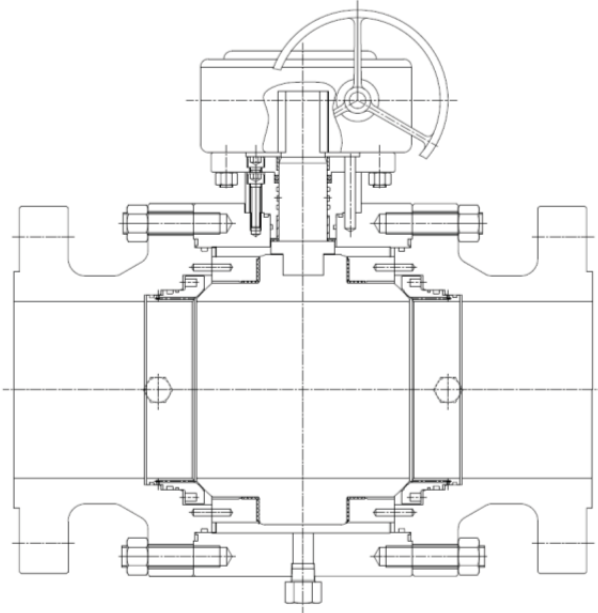

### **Ball valve with reduced bore**

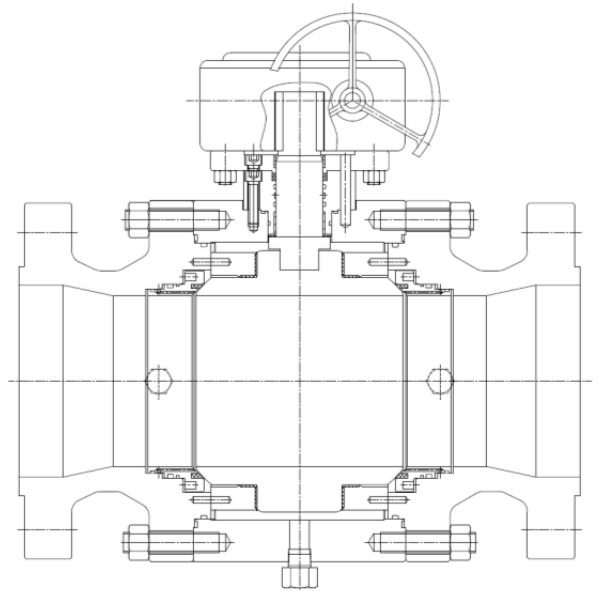

In addition to full bore trunnion ball valves, AFFCO also manufactures the reduced bore trunnion ball valves to meet different requirements of customers which not only lowers the cost but also satisfies special requirements of customers.

### Main size and weight

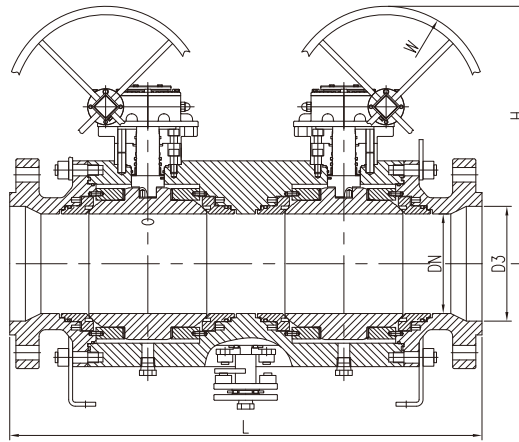

### Main size

Pressure Rating	Size		Dimensions(mm)					
	DN	NPS	L		D3	DN	H	W
			RF	RTJ				
Class150	150	6	450	-	150	100	350	300
	200	8	695	-	201	150	405	300
	250	10	797	-	252	201	470	300
	300	12	926	-	303	252	600	400
	350	14	937	-	334	252	600	400
	400	16	1080	-	385	303	675	400
	450	18	1212	-	436	334	800	500
	500	20	1400	-	487	385	890	500
Class300	600	24	1670	-	589	487	980	600
	150	6	488	-	150	100	350	300
	200	8	714	-	201	150	425	300
	250	10	858	-	252	201	480	300
	300	12	974	-	303	252	620	400
	350	14	974	-	334	252	620	400
	400	16	1130	-	385	303	696	400
	450	18	1266	-	436	334	880	600
Class600	500	20	1460	-	487	385	1050	750
	600	24	1720	-	589	487	1100	750
	50	2	378	-	50	38	240	300
	80	3	454	-	74	50	280	300
	100	4	540	-	100	74	340	300
	150	6	652	-	150	100	358	400
	200	8	818	-	201	150	445	400
	250	10	1015	-	252	201	498	400
	300	12	1152	-	303	252	665	400
	350	14	1158	-	334	252	665	500
	400	16	1310	-	385	303	738	600
Class900	450	18	1420	-	436	334	920	750
	500	20	1553	-	487	385	1100	750
	600	24	1850	-	589	487	1200	750
	50	2	520	-	50	38	260	300
	80	3	610	-	74	50	310	300
	100	4	457	-	100	74	380	300
	150	6	685	-	150	100	410	300
	200	8	851	-	201	150	485	400
	250	10	1114	-	252	201	550	400
	300	12	1300	-	303	252	740	400
	350	14	1320	-	322	252	740	500
	400	16	1450	-	373	303	830	600
450	18	1620	-	423	322	1030	750	
500	20	1780	-	471	373	1140	750	
600	24	1950	-	570	471	1250	750	



**Metal Seated Double Block and Bleed Valve ( DBB Valve)**

In general metal seated trunnion DBB Valve are offered with cast steel, however as per project and customer requirements AFFCO can provide forged steel metal seated trunnion DBB Valve as well. The flange dimensions and face to face dimensions are same for both cast and forged steel trunnion DBB Valve.

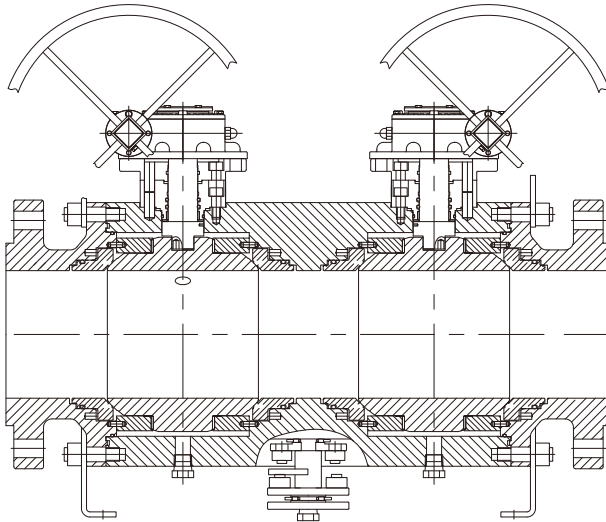

**Double Block and Bleed Valve ( DBB Valve) with full bore**

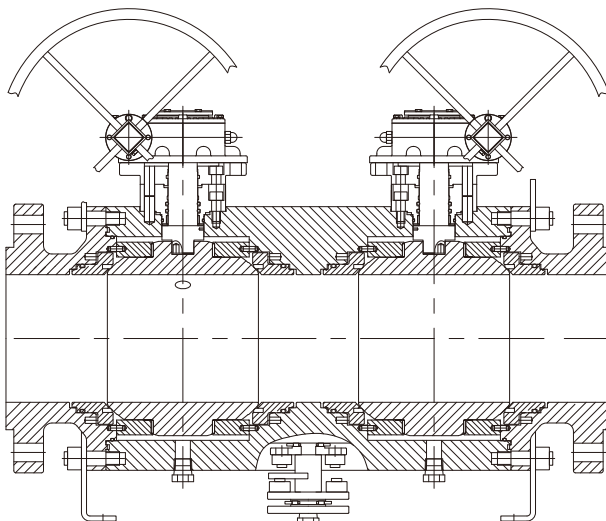

In addition to reduced bore trunnion DBB valves, AFFCO also manufactures the reduced bore trunnion DBB valves to meet different requirements of customers which not only lowers the cost but also satisfies special requirements of customers.



# WHERE SOLIDARITY AND COOPERATION COME TOGETHER.



## **Website**

[www.affco-flowcontrol.com](http://www.affco-flowcontrol.com)

## **AFFCO Flow Control (Shanghai) Co., Ltd**

No. 99 Desheng Road,  
Economic and Technological Development  
Area, Feng Xian, Shanghai 201411

Tel: +86 (21) 5814 7017

Fax: +86 (21) 5814 7885

Web: [www.affco-flowcontrol.com](http://www.affco-flowcontrol.com)

Email: [sales@alfacasting.com](mailto:sales@alfacasting.com)

## **AFFCO Flow Control Europe B.V.**

Opweg 90a, 2871 NG, Schoonhoven,  
The Netherlands

Tel: +31 (0)85 877 27 56

Fax: +31 (0)85 782 51 01

Web: [www.affco-flowcontrol.com](http://www.affco-flowcontrol.com)

Email: [sales.info@affco-flowcontrol.com](mailto:sales.info@affco-flowcontrol.com)

## **AFFCO Flow Control Pte Ltd**

237, Pandan Loop, #05-04, Westech  
Building

Singapore 128424

Tel : +65 65709920

Fax : +65 65709923

Email: [info@affco.com.sg](mailto:info@affco.com.sg)

## **AFFCO Flow Control Mideast FZE**

SAIF Suite Y-16

P.O. BOX 123612

Sharjah – U.A.E.

Tel: +971 6 5220879

Email: [info@affcomideast.ae](mailto:info@affcomideast.ae)

## **AFFCO Flow Control UK Ltd.**

Unit 7, Stafford Park 12, Telford,  
Shropshire, TF3 3BJ, England

Tel: +44 (0)1952 459 338

Email: [sales@affco-flowcontrol.co.uk](mailto:sales@affco-flowcontrol.co.uk)